



Cognibotics

HKM1800

Have you appreciated high speed but been lacking reach? Or have you had the reach but had to use an oversized and slow robot? Cognibotics HKM1800 will enable you to take your productivity to a new level. It provides a 1800 mm radial reach at world class speeds, with a small footprint and very high energy efficiency.

In short:

- 1800 mm radial reach
- 2000 mm pick cycle 1,6 s
- Energy efficient
- Flexible mounting
- Active Motion Stabilization
- Unlimited tool rotation

Long Reach with High Speed at low energy consumption

The HKM 1800 provides through its unique, patented arm structure a new, fourth, motion principle for fast pick-and-place. Compared to existing scara, delta and traditional 6-axis robots it is built with fewer degrees of freedom, optimized for pick-and-place applications with superior performance.

Built with high strength, low weight components the HKM is one of the fastest robots on the market, offering an unprecedented combination of rigidity and low weight. With 80% of the manipulator weight located in its stationary base, the energy consumption is very low.

The long reach enables you to substitute several conventional robots to serve many pick-and-place areas without the need for supporting structures.

Compact Robot

Small footprint and the possibility to have robots easily work within each other's workspaces, gives you the opportunity to shrink your production space. The robot is easily installed in a variety of positions to fit the application.

Cognibotics Unique Competence

Cognibotics' world class competence helps you integrate HKM robots into special purpose applications, your standard cells or machines.

Active Motion Stabilization

With an active motion feedback from the robot wrist each movement becomes perfectly controlled and distinct. The control system efficiently compensates for payload variations and deviations, thereby providing the shortest possible cycle times for a pick & place robot without compromising the smoothness of the motion.

Unlimited tool rotation

The tool flange of the HKM can rotate without angular limits thanks to an efficient wrist axis, which both provides a slim design and high robustness of the tool complete assembly.

Improved cable routing

Cables are routed through a well protected and easy to access cavity in the base of the robot and allows for a multitude of installation and mounting options. The increased protection minimizes the need for maintenance and increases the slimness and robustness of the robot installation.

Specification

HKM1800	
Max reach	1 800 mm
Nominal payload	2 kg
Max payload	7,5 kg
Max payload CoG offset	
-Vertical	200 mm
-Horizontal	50 mm
No of axes	4
Mounting	Floor, Ceiling
Integrated signal & buses	8 x 12VA
	2 x twisted pair
Integrated air	2 x 6 mm outer diameter

Performance

HKM1800	
2 kg pick cycle	
25-1000-250 mm	3600 cycles/hour
2 kg pick cycle	
25-2000-250 mm	2250 cycles/hour
Max TCP Acceleration	10 g
Acceleration time 0-1m/s	0,04 s

Technical

HKM1800	
Electrical	
Supply Voltage	230 V 50 Hz
Fuse	16 A slow fuse
Power Consumption	
-1-2 m motion	<1 kW
-0,5-1 m motion	<1 kW
Physical	
Robot Height	1036 mm
Foot Print	280 x 320 mm
Weight	<100 kg
Environment	
Ambient Temp Manipulator	+5°C to +35°C
During Operation	+5°C to +40°C
	+41°F to +104°F
Transport & Storage	- 25°C to +55°C
	-13°F to +131°F
Peaks not running <24hours	<70°C / +158°F

Movement

Axis	Range	Max. speed
Axis 1	± 180°	600 °/s
Axis 2	± 70°	550 °/s
Axis 3	± 60°	250 °/s
Axis 4	Unlimited	1500 °/s

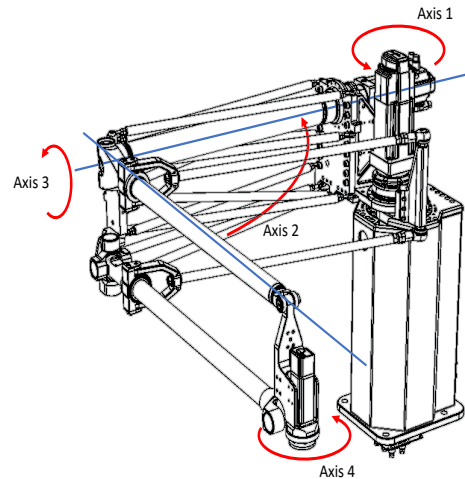

Working Range

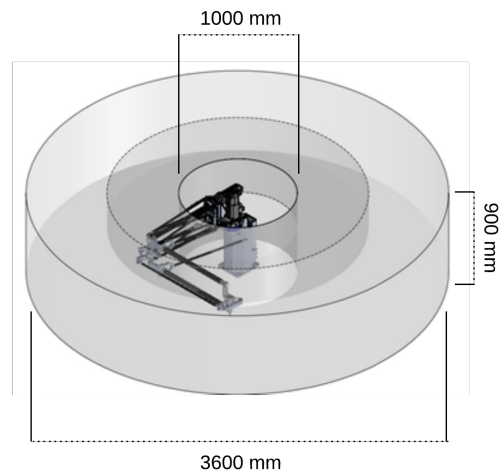

Get in touch:

Phone: +46 46 286 59 90
 E-mail: info@cognibotics.com
www.cognibotics.com